

1. HANDLING

Before installation, these installation and operating instructions must be read carefully.
The product must be lifted and handled with care.

2. APPLICATIONS

CB, CBI: Designed to handle clean, thin, non-aggressive water and non-explosive liquids, no solid particles.

HBI, HBN: Designed to handle clean, thin and non-explosive liquid without particles.
That also can be used in light industry application.

3. WORKING LIMITS

CB, CBI: —

Max. operating pressure:
0 °C to +40 °C → 10 bar, +41 °C to +90 °C → 6 bar.
Max. liquid temperature: 0 °C ~ +90 °C.
Max. ambient temperature: +55 °C.
Min. inlet pressure:
According to the NPSH curve + a safety margin of 0.5m.
Max. inlet pressure: Limited by the max. operating pressure.

HBI, HBN: —

Max. operating pressure: 10 bar.
Max. liquid temperature:
HBI-- 0 °C ~ +90 °C, HBN-- -15 °C ~ +120 °C.
Max. ambient temperature: +40 °C.
Min. inlet pressure:
According to the NPSH curve + a safety margin of 0.5m.
Max. inlet pressure: Limited by the max. operating pressure.

4. INSTALLATION

● The pump may be installed as shown in Fig. 1.

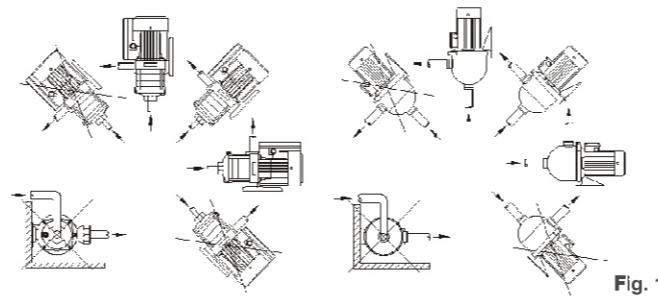

Fig. 1

● Position of terminal box (Fig.2)

The terminal box can be turned to three positions before the pump is installed.

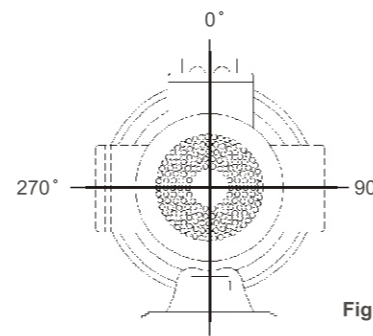

Fig. 2

● Proper installation (Fig.3)

A= Eccentric adapters
B= Positive lift
C= Good immersion
D= Wide bends
E= Suction pipe diameter >= pump port diameter
F= Suction lift. Depends on pump and installation (*)
G= Pipes must not exert stress on pump but on independent supports
H= Foot valve.
(*) The suction lift is determined by liquid temperature, altitude, flow resistance and NPSH required by the pump.

Notes:

A general rule: When the suction pipe is longer than 10 meters or the suction lift is greater than 4 meters, the diameter of the suction pipe must be larger than that of the pump suction port.

● Improper installation (Fig.3)

1 = Tight bends: high flow resistance
2 = Insufficient immersion: air suction
3 = Negative lift: air pockets
4 = Pipe diameter < pump port diameter: high flow resistance.

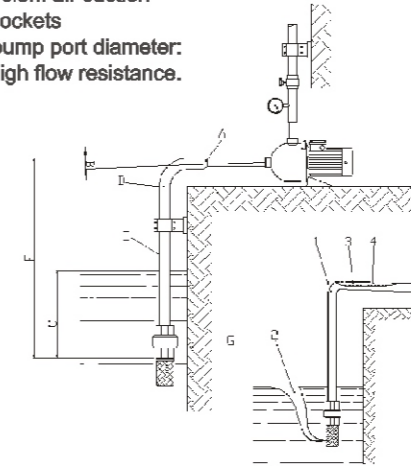

Fig.3

5. ELECTRICAL CONNECTION

- To connect, proceed as shown on the inside of the terminal board cover.
- To check the direction of rotation (Three-phase motor only) -Anticlockwise rotation.

6. Others (Fig.4)

● Priming

Before start up, fill the pump body and suction pipe through the priming plug, bleeding off all the air.

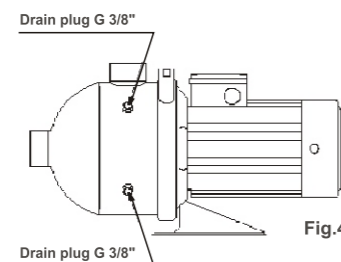
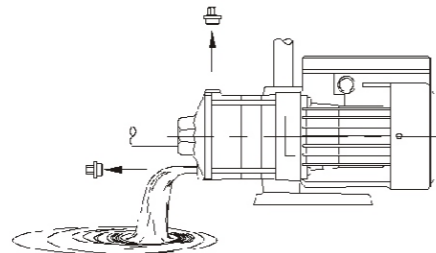

Fig.4



● Maintenance

No routine maintenance is required.

● Frost protection

Pumps which are not being used during periods of frost should be drained to avoid damage.
Remove the priming and drain plugs and allow the pump to drain.

7. TROUBLE SHOOTING

Fault	Possible cause
Pump does not run when motor is turned on	<a> Supply failure.
	 Main contacts in motor starter are not making contact or the motor coil is faulty.
	<c> Control circuit fuses have cut or are defective.
	<d> Pump is blocked by unknown matters.
	<e> Motor is failure
Pump runs but delivered	<a> Pump is not fill with liquid.
	 Pump is blocked by unknown matters.
	<c> The suction or discharge pipe is blocked by unknown matters.
	<d> The foot or non-return valve is blocked or failure.
	<e> The suction pipe is leakage.
	<f> The suction lift is too great.
	<g> The air is in suction pipe or pump.
Pump capacity is not constant or is reduced	<a> Pump takes in air.
	 The pump, suction pipe or discharge pipe is partly blocked by unknown matters.
	<c> The inlet pressure is too low.
	<d> Wrong direction of rotation (three phase).
	<e> The suction lift is too great.
	<f> The foot or non-return valve is partly blocked.
Starter overload cut off immediately when the power is switched on.	<a> Overload setting is too low.
	 The cable connection is loose or faulty.
	<c> One fuse is blown.
	<d> Pump is not free to run.
	<e> Contacts in overload are faulty.
	<f> The motor winding is defective.
	<g> Low voltage (Especially at peak time).

We reserve the right to make specification changes without notice and without incurring liability.



STAIRS PUMPS



Installation and operating manual

CB, CBI, HBI, HBN series

Instruction for installation and operating